

FLO KING COUNTERFLOW ACTION USING THE ORIGINAL 4 IN 1 IN-TANK FILTER SYSTEM

Filtration is only half the battle in capturing particulates. *Agitation is the other half.* Without effective solution movement, a large percentage of particles and other contaminants descend to the bottom of the tank—escaping entrapment by the filter media.

The **Flo King** system solves this problem by providing **counterflow action** as a natural byproduct of filtration. As solution is expelled at a high rate from the directable pump discharge port, the **Flo King** system creates a rolling counterflow motion that continually suspends particles for quick, efficient removal.

This counterflow action cleanses the solution surface by skimming and then dragging particulates, oils, and other contaminants down to the filter media. That means cleaner entry for parts and fewer coating adhesion problems. It also frequently eliminates the need for separate air and mechanical agitation systems!

- 1 PUMPS 2 FILTERS 3 AGITATES 4 TREATS

Solution circulation is a natural byproduct of filtration using the **FLO KING** filter system.

Unique **counterflow motion** continually skims surface and helps prevent sediment buildup at tank bottom.

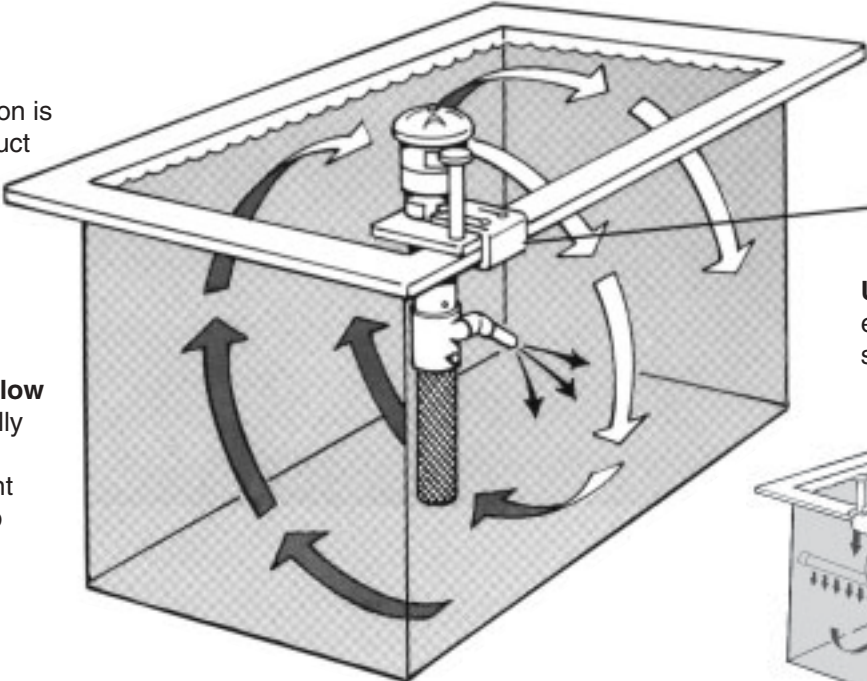

Universal Bracket eliminates clamps, screws, bolts, etc.

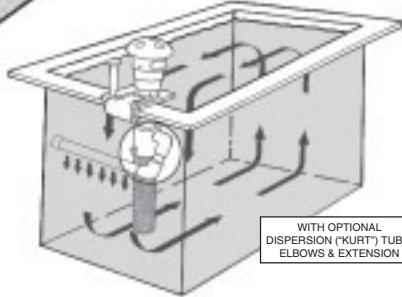

WITH OPTIONAL DISPERSION ("KURT") TUBE, ELBOWS & EXTENSION

Pioneers of In-Tank Filtration ★ www.floking.com